

IMPORTANT - USE ONLY IN DRY LOCATIONS. READ CAREFULLY BEFORE INSTALLING FIXTURE. RETAIN THESE INSTRUCTIONS FOR FUTURE REFERENCE. THIS PRODUCT MUST BE INSTALLED IN ACCORDANCE WITH THE NATIONAL ELECTRICAL CODE AND ALL APPLICABLE LOCAL CODES, BY A PERSON FAMILIAR WITH THE CONSTRUCTION AND OPERATION OF THE PRODUCT, AND THE HAZARDS INVOLVED. PROPER GROUNDING IS REQUIRED FOR SAFETY.

NOTE - TRACK IS UL LISTED STRICTLY FOR 120V, 60Hz, 20A OR 277V, 60Hz, 20A. NOT FOR USE WITH REMOTE TRANSFORMER(S).

DIMMING - INCANDESCENT LUMINAIRE ACCEPTS STANDARD ROTARY OR SLIDE DIMMER. SELECT DIMMER WITH AMPLE CAPACITY FOR TOTAL NUMBER OF TRACK FIXTURES. ELECTRIC LOW VOLTAGE FIXTURES REQUIRE USE OF SOLID-STATE (ELECTRONIC) DIMMER CONTROL CAPABLE OF DIMMING TRANSFORMERS. EXAMPLE: LUTRON, COMPACT FLUORESCENT AND HID FIXTURES CANNOT BE DIMMED. FOR LED LUMINAIRE, REFER TO THE FIXTURE'S INSTALLATION SHEET.

SISTEMALUX TWO CIRCUITS TRACK WITH DATA PREPARATION INSTRUCTIONS

IF THE TRACK NEEDS TO BE CUT ON-SITE, COMPLETE THE FOLLOWING STEPS TO ENSURE FUNCTIONAL TRACK:

A- USING A METAL SAW, CUT THE TRACK SECTION STRAIGHT.

B- USING THE CUTTING TOOL (ARTICLE 0389 TO BE ORDERED SEPERATELY), INSERT THE TIP AROUND THE TRACK CONDUCTORS (1) AND CUT THE 4 POWER CONDUCTORS TO RECESS AT LEAST OF 0.196" (2)

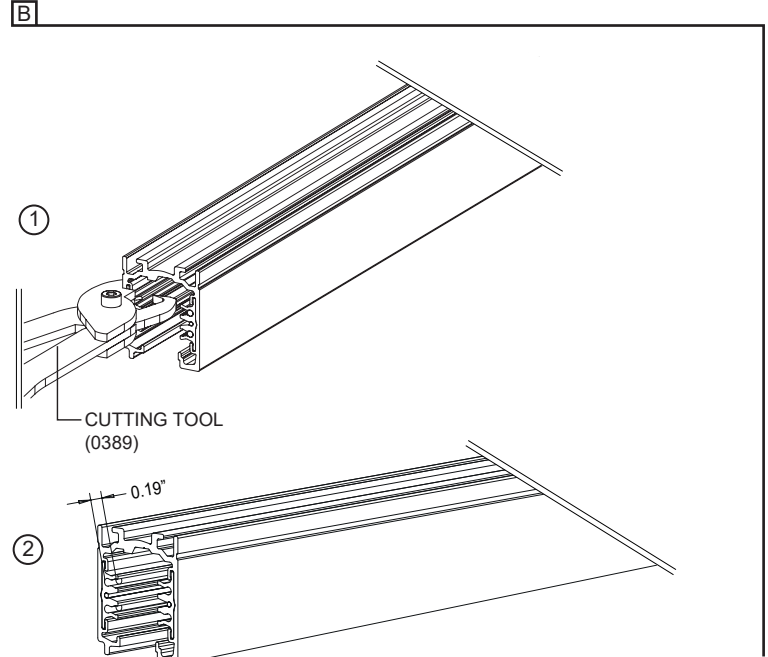
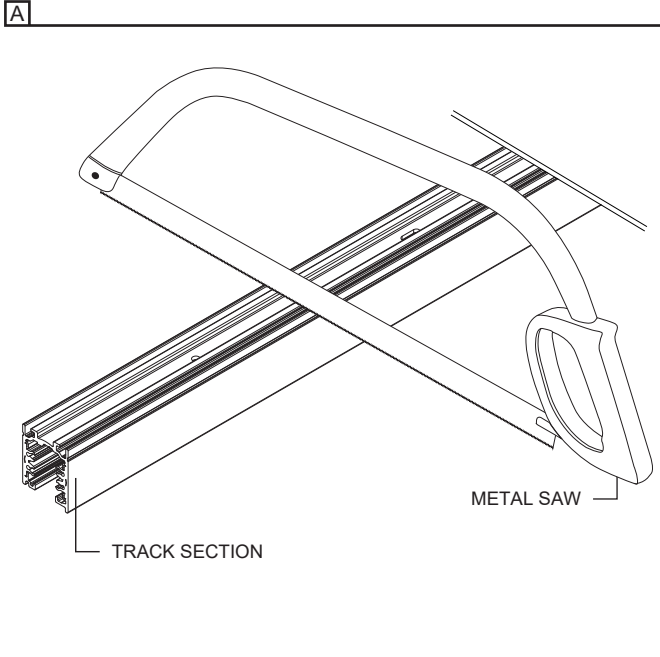

DRILLING NEW HOLES (FOR SURFACE MOUNT)

TRACK SECTION ≤ 4' (1.22M) = 2 HOLES

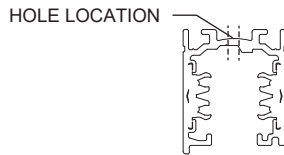
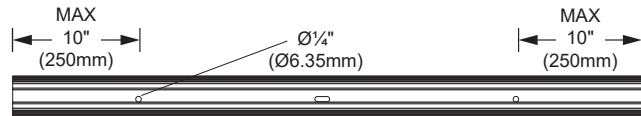

TRACK SECTION > 4' (1.22M) = HOLES EVERY 3' (920mm)

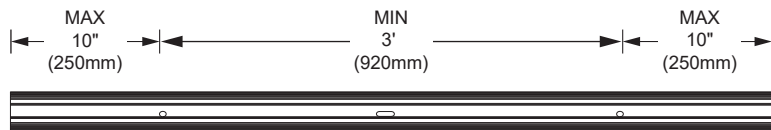

MINIMUM HEIGHT TRACK INSTALLATION

TRACK SYSTEM MUST BE INSTALLED A MINIMUM OF 5'(1.52m) ABOVE THE FLOOR.

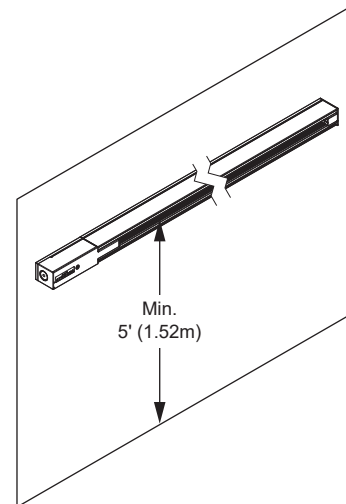

PENDANT INSTALLATION
120V or 277V

MAKE SURE THE TRACK IS HELD IN PLACE BY THE AIRCRAFT CABLES, NOT BY THE POWER CABLE. KEEP THE POWER CABLE LOOSE.

DETAIL 1:

- A- PLACE PLASTIC ANCHOR SCREWS (**INCLUDED**) IN THE CEILING AT THE REQUIRED DISTANCE.
- B- PASS SCREW THROUGH THREADED REDUCER RING AND SECURE SCREW INTO PLASTIC ANCHOR SCREW.
- C- FASTEN THE MOUNTING COUPLING CYLINDER ON THREADED REDUCER RING.
- D- ADJUST CABLE LENGTH WITH THE SELF-LOCK CABLE GRIPPER. IF YOU NEED TO ADJUST THE CABLE FOR MORE THAN 6"(152mm), REMOVE THE CABLE FROM THE SELF-LOCK CABLE GRIPPER AND CUT IT TO DESIRED LENGTH. WHEN SET, TIGHTEN THE SELF-LOCK CABLE GRIPPER.

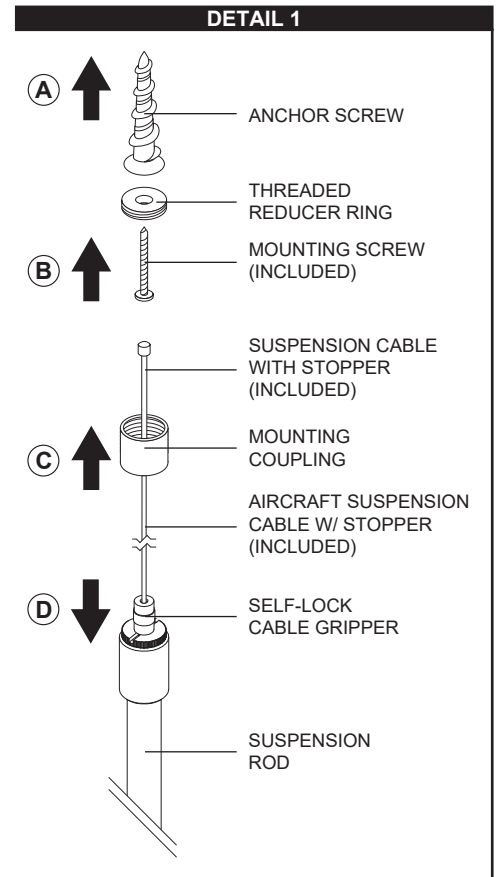
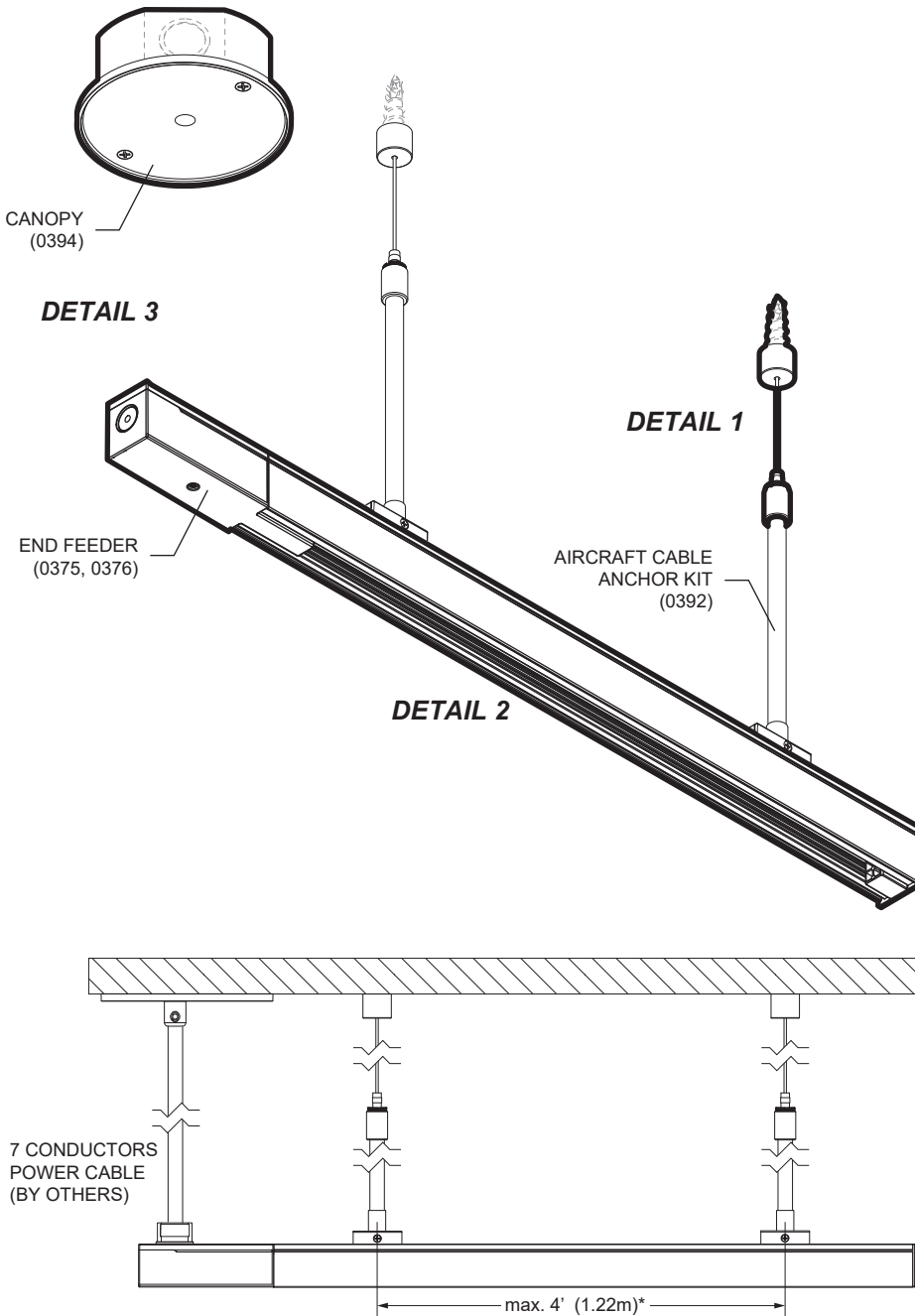

*REFER TO P.1 FOR CUSTOM HOLE DRILLING INSTRUCTIONS

DETAIL 2:

A- FASTEN THE MOUNTING CLIPS (**INCLUDED**) TO THE SUSPENSION RODS USING THE PHILLIPS SCREWS (**INCLUDED**).

B- UNFASTEN THE MOUNTING CLIP SIDE PHILLIPS SCREW AND SLIDE IT ON THE TRACK SECTION.

C- FASTEN THE SCREW UNTIL THE MOUNTING CLIP IS SECURILY HELD INTO PLACE.

***REMOVE END CAP TO ALLOW CONTINUOUS LINE INSTALLATION. (SEE PAGE 6)**

DETAIL 2

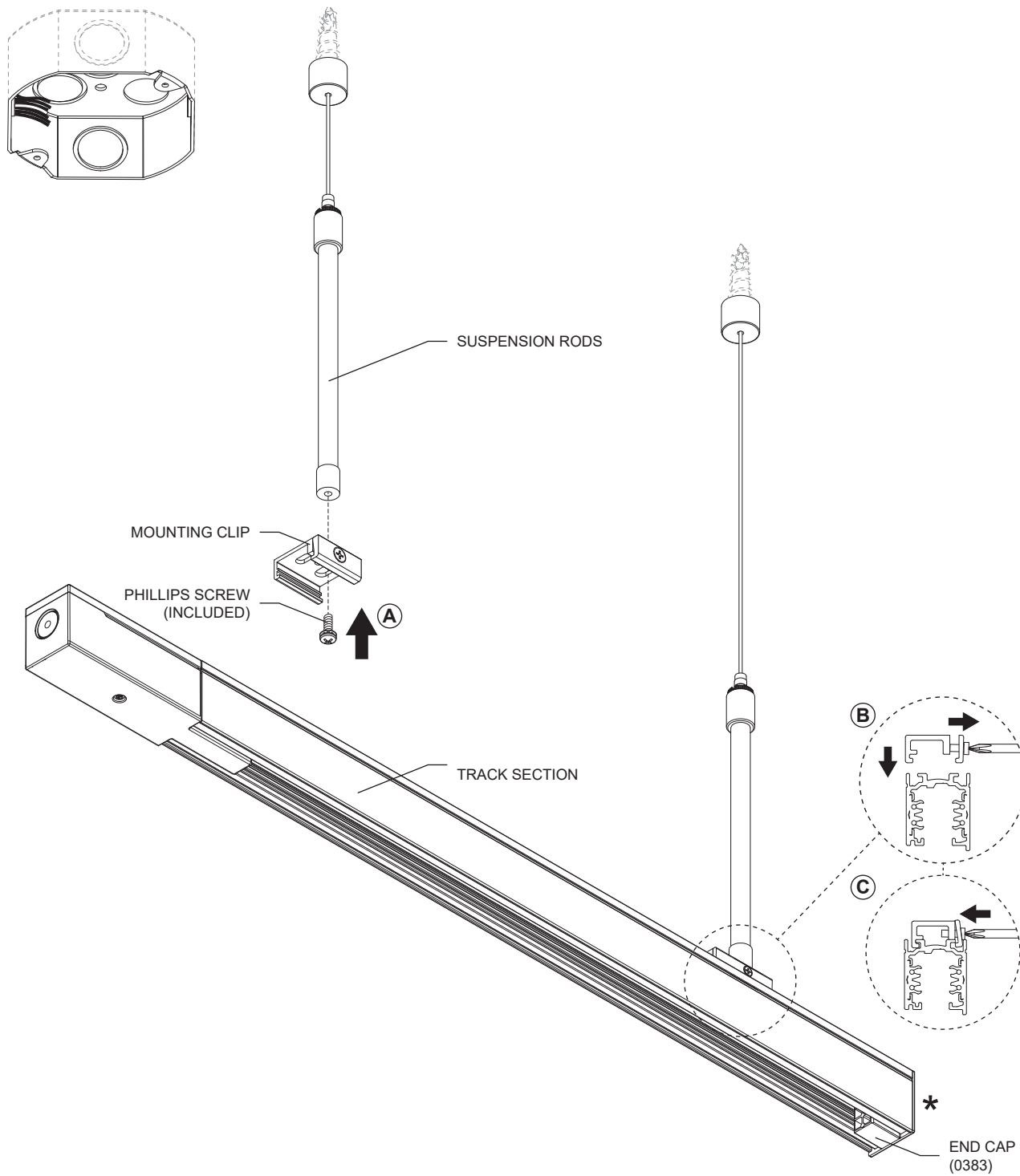

DETAIL 3:

- A- UNFASTEN END FEEDER COVER'S PHILLIPS SCREW.
- B- PASS THE POWER CABLE THROUGH THE CABLE STRAIN RELIEF (INCLUDED) THEN INSERT IT INSIDE THE END FEEDER BRACKET HOLE.
- C- MAKE THE NECESSARY CONNECTIONS (FOLLOWING POLARITY MARKINGS) INSIDE THE END FEEDER BRACKET.
- D- FASTEN COVER BACK ON.
- E- PASS THE POWER CABLE THROUGH THE CANOPY AND ADJUST TO DESIRED LENGTH. MAKE SURE THAT YOU USE A PROPER STRAIN RELIEF TO SECURE THE CABLE IN JUNCTION BOX. ENLARGE THE CANOPY HOLE IF NECESSARY. **THE POWER CABLE MUST NOT BE USED TO HOLD THE TRACK IN PLACE.**
- F- MAKE WIRE CONNECTIONS INSIDE THE JUNCTION BOX USING TWIST CONNECTORS (NOT INCLUDED).
- G- SCREW CANOPY TO THE JUNCTION BOX WITH (2) PHILLIPS SCREWS (INCLUDED).

DETAIL 3

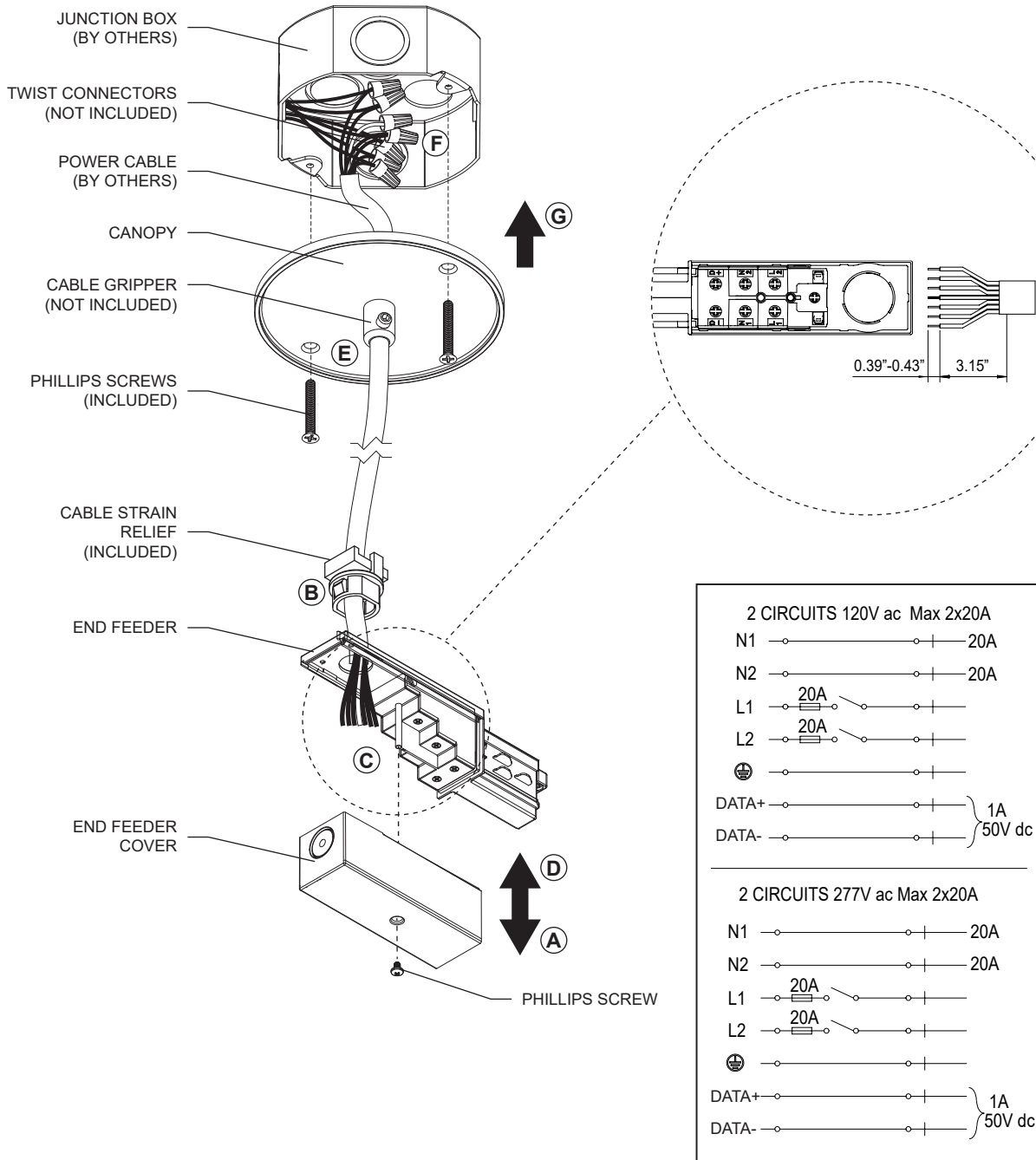

FINAL ASSEMBLY

INSERT END FEEDER BRACKET INTO TRACK SECTION

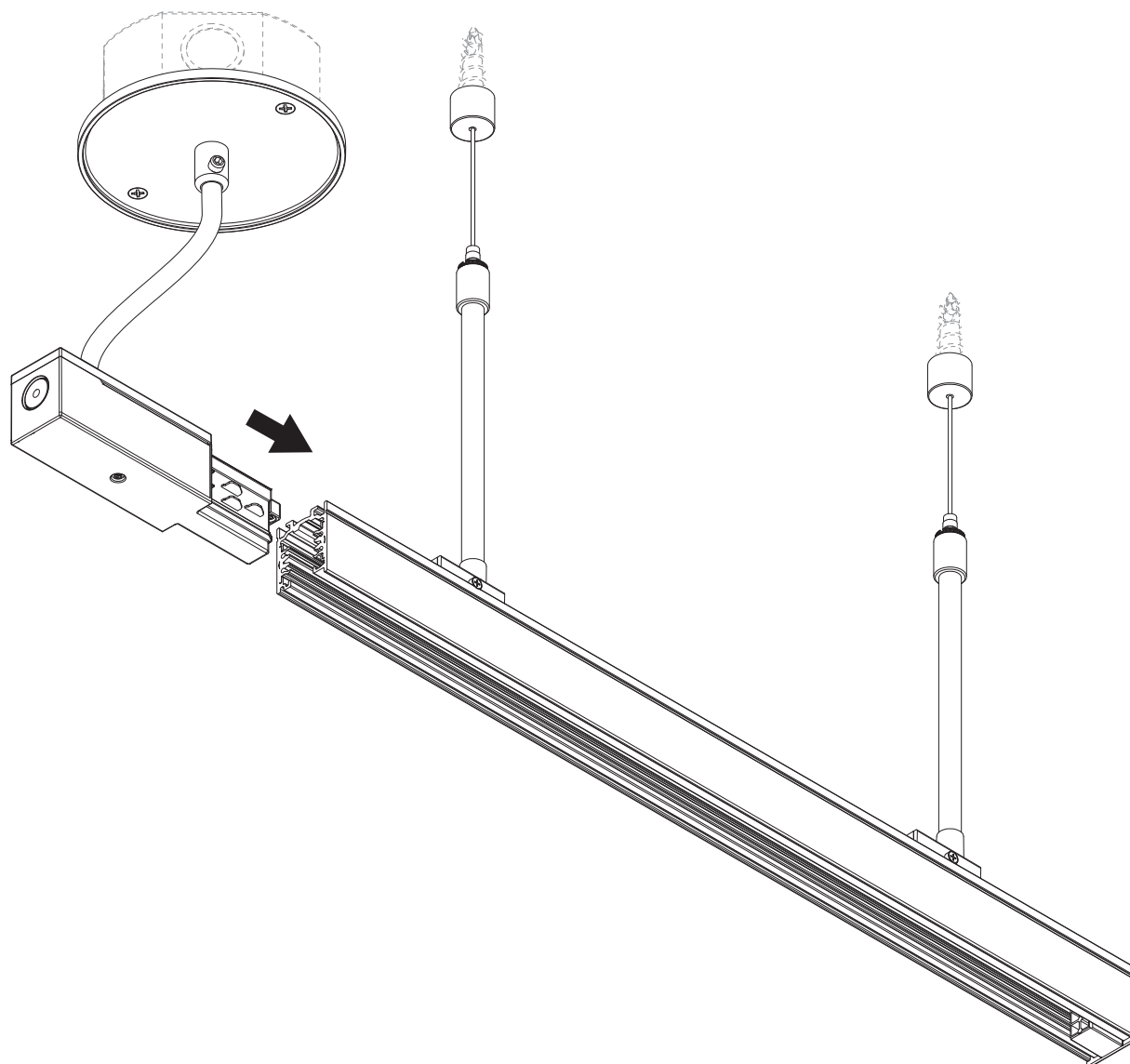

CONTINUOUS LINE CONNECTOR INSTALLATION

- 1- REMOVE THE PREVIOUS TRACK'S END CAP
- 2- ALIGN THE DIRECT COUPLER'S GUIDE LUG WITH THE TRACK'S TOP GROOVE.
- 3- INSERT THE DIRECT COUPLER INTO THE END OF THE TRACK (**SEE P.1 FOR TRACK CONDUCTOR PREPARATIONS**), ENSURING THAT THE GUIDE LUG ENTERS THE GROOVE AT THE TOP OF THE TRACK.

NOTE - TRACKS ARE POLARIZED, SO CONNECTORS CAN ONLY BE INSTALLED IN THE TRACK IN ONE DIRECTION. I, L, T AND X-CONNECTORS ARE PRE-WIRED, AND SHOULD NOT BE RE-CONFIGURED ON THE FIELD.

